

TRANSMITTER

TR-A/V/VMT



FUNCTION

The TR-A/V/VMT transmitter connected to a dedicated transducer (accelerometer, velocimeter or velomitor) measures absolute vibration of any machine support and is capable of directly interfacing with an acquisition system (PLC or DCS) in 2-wire (4-20 mA current loop) or 3-wire technique.

GENERAL DESCRIPTION

The TR-A/V/VMT transmitter processes the signal coming from the transducer connected to it and converts it into a proportional analogue signal at the measured magnitude.

It can be installed in a secure area and connected by means of certified barriers to intrinsic safety transducers positioned in a classified area.

It comes complete with terminal strips for connection to a power supply, input and output signals and a BNC for connection to an analyser.

TECHNICAL CHARACTERISTICS	TR-A/V/VMT
Composition	<ul style="list-style-type: none"> • Transmitter with provision for fastening to a DIN guide • TR-A interfaceable with accelerometers with a sensitivity of 100 mV/g (TA-18 – TA-18/S) • TR-V interfaceable with velocimeters with a sensitivity of 21.2 mV/mm/s (T1-40 – T1-40V – T1-40BF – T1-38 – T1-38V – T1-38BF) • TR-VMT interfaceable with velomitor TV-22 (3,94 mV/mm/s)
Power supply	<ul style="list-style-type: none"> • 24 VDC nominal • 18-30 VDC for 2-wire version (see Figure 1 for the maximum load) • 24-35 VDC for 3-wire version
External connections	<ul style="list-style-type: none"> • Terminal strip for connection to a PLC/DCS (2- or 3-core screened cable, max. cross-section 2.5mm²) • Terminal strip for connection to a transducer (2- or 2-core screened cable, max. cross-section 2.5mm²) • BNC for connection to an analyser
Operating temperature range	<ul style="list-style-type: none"> • -35°C ÷ +70°C
Type of measurement	<ul style="list-style-type: none"> • Absolute vibration
Dynamic performance	<ul style="list-style-type: none"> • 5 ÷ 10.000Hz
Linearity	<ul style="list-style-type: none"> • ± 2% over the entire measurement range and within the operating temperature limits indicated
Insulation	<ul style="list-style-type: none"> • ≥ 10⁸ Ω between signals and container
Possible provisions at the time of order	<ul style="list-style-type: none"> • Transducer type • Magnitude measured • Measurement mode • Measurement range • Filters • Power supply type • Output type



TR-A/V/VMT

Maximum load

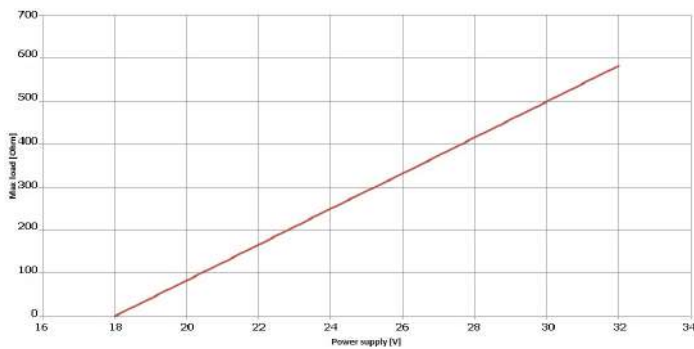

Dimensions

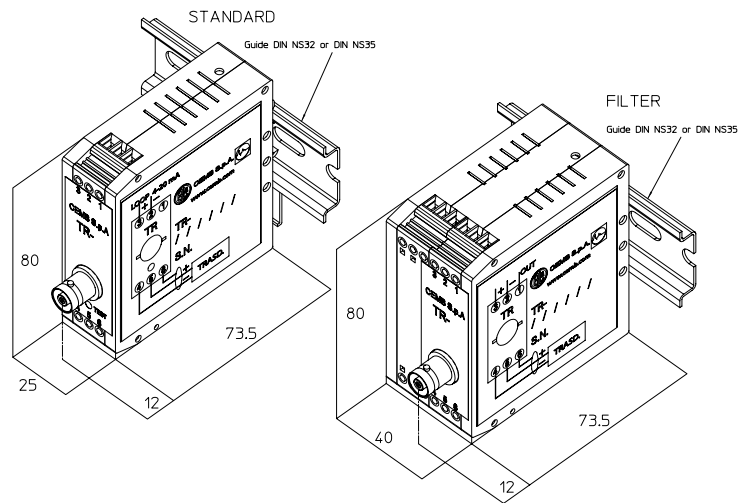

ORDER INFORMATION

TR - / / / / / / / /

A: TRANSDUCER TYPE

V	velocimeter
A	accelerometer
VMT	velomitor

B: MAGNITUDE MEASURED

0	displacement (only for TR-V and TR-VMT)
1	speed
2	acceleration (only for TR-A)

C: MEASUREMENT MODE

0	RMS
1	peak
2	peak-peak

D: MEASUREMENT RANGE

0	0 ÷ 100 μm	6	0 ÷ 1 g
1	0 ÷ 200 μm	7	0 ÷ 5 g
2	0 ÷ 500 μm	8	0 ÷ 10 g
3	0 ÷ 10 mm/s	9	0 ÷ 20 g
4	0 ÷ 20 mm/s	S	special (to be defined)
5	0 ÷ 50 mm/s		

E: HIGH-PASS FILTER

0	without filter	4	50 Hz
1	5 Hz	5	100 Hz
2	10 Hz	6	1000 Hz
3	20 Hz	S	special (to be defined)

G: POWER SUPPLY TYPE

2	2-wire (current loop)
3	3-wire

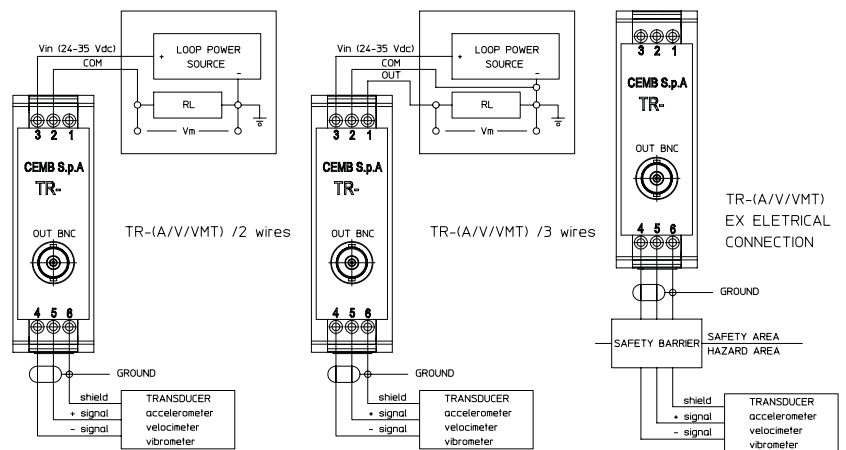

ORDER EXAMPLE:

TR - A / B / C / D / E / F / G / H
A 1 0 3 2 2 3 0

A = accelerometer transducer 2 = 10 Hz high-pass filter
1 = measurement in speed 2 = 1000 Hz low-pass filter
0 = RMS measurement 3 = 3-wire power supply
3 = 0 - 10 mm/s measurement range 0 = 4 - 20 mA

F: LOW-PASS FILTER

0	without filter	4	5000 Hz
1	100 Hz	5	10000 Hz
2	1000 Hz	S	special (to be defined)
3	2500 Hz		

N.B: the low-pass filter frequency must be at least double that of the high-pass filter.

H: OUTPUT TYPE

0	4 - 20 mA
2	0 - 10 VDC (only for 3 wires)

All the data and features mentioned in this catalogue are purely for information and do not constitute any commitment on the part of our company, which reserves the right to make any and all alterations it may consider suitable without notice.